

REVISION RECORD			
REV	ECN	DESCRIPTION	DATE
10-2	15-0267	针宽改为0.8mm, 并增加倒角	07/06/15

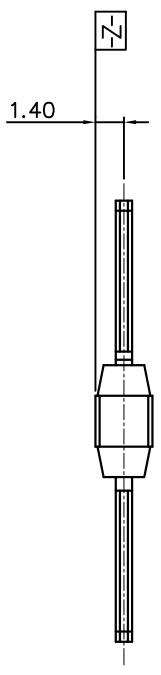
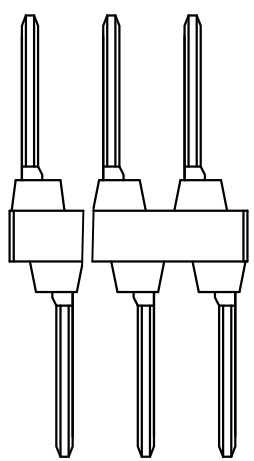
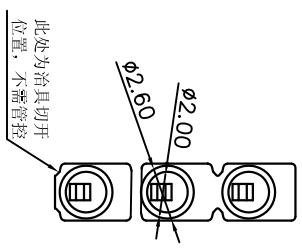
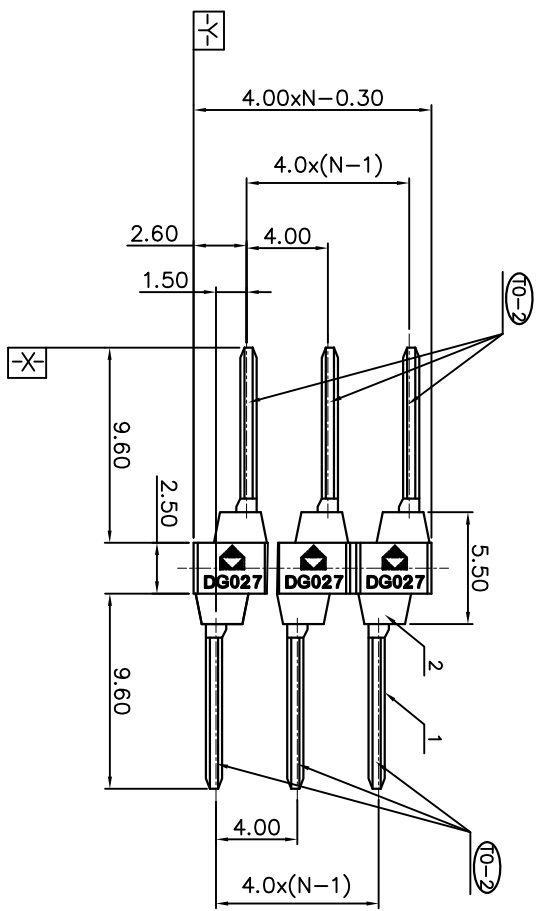

- NOTES:
1. DIMENSION SHALL BE INTERPRETED PER ASME Y14.5-2009.
 2. PITCH: 4.0MM, POLES: N=1~3P
 3. RATED VOLTAGE/CURRENT: UL1977 600V/9A(01P), 250V/9A(02P/03P) IEC 160V/9A
 4. OPERATION TEMPERATURES: -40°C~+105°C
 5. RATED IMPULSE VOLTAGE: 2.2KV/MIN
 6. INSULATION RESISTANCE: 5000MΩ/DC1000V
 7. UNDIMENSIONED TOLERANCES:

PITCH RANGE IN MM	NOMINAL DIMENSION RANGE IN MM	OVER 6 TO 10	OVER 10 TO 24	OVER 30 TO 60	OVER 60 TO 100	OVER 100 TO 150	OVER 150 TO 150
±0.10±0.15	±0.25±0.20	±0.30±0.30	±0.50±0.70	±1.00±0.05	±1.0	±1.0	±1.0

ITEM	NAME OF PART	NO. OF PART	QTY	MATERIAL	NOTES
2	DG027-4.0-包塑件	3097J2906A(H)	XX/6	PA66+25%GF	UL94V-0
1	DG027-4.0-TERMINAL	3097B00010(H)	XX	COPPER	SN PLATED

TOLERANCES EXCEPT AS NOTED	FINISH:	NAME:
MM (INCH)	PART NO.:	DEGSON
XXX ±	APPD:	DEGSON ELECTRONICS CO., LTD
XXX ±	CHKD:	宁波高压电子有限公司
XXX ±	DFTI: XLM 09/11/14"	DG027-4.0-XXP-19-00A(H)
ANGLES ± 1°	DO NOT SCALE DRAWING	ASSEMBLY DRAWING
THIRD ANGLE PROJECTION	SCALE	REV
	N/A	TO-2
		1/1

A 8 7 6 5 4 3 2 1