

REVISION RECORD				
REV	ECO	DESCRIPTION	DRFT	DATE

Notes:

1. Pitch:7.5mm ,Poles:2-XXP
2. Rated voltage/current:UL 300V/10A
VDE 450V/24A
3. Operation temperatures:-30℃~+120℃
4. Withstanding Voltage:AC2000V/1Min
5. Insulation Resistance:5000MΩ/DC1000V
6. Wire Range:22~14AWG, 2.5mm²
7. Max. Torque Value:M3, 5.10kgf. cm
8. Undimensioned Tolerances:

Pitch range in mm		Nominal dimension range in mm				—
to	over	over	to	over	over	over
6	6 to 10	10 to 24	30 to 60	60 to 100	100 to 150	150
±0.10	±0.15	±0.25	±0.2	±0.3	±0.5	±0.7
						±1.0
						0.05/10

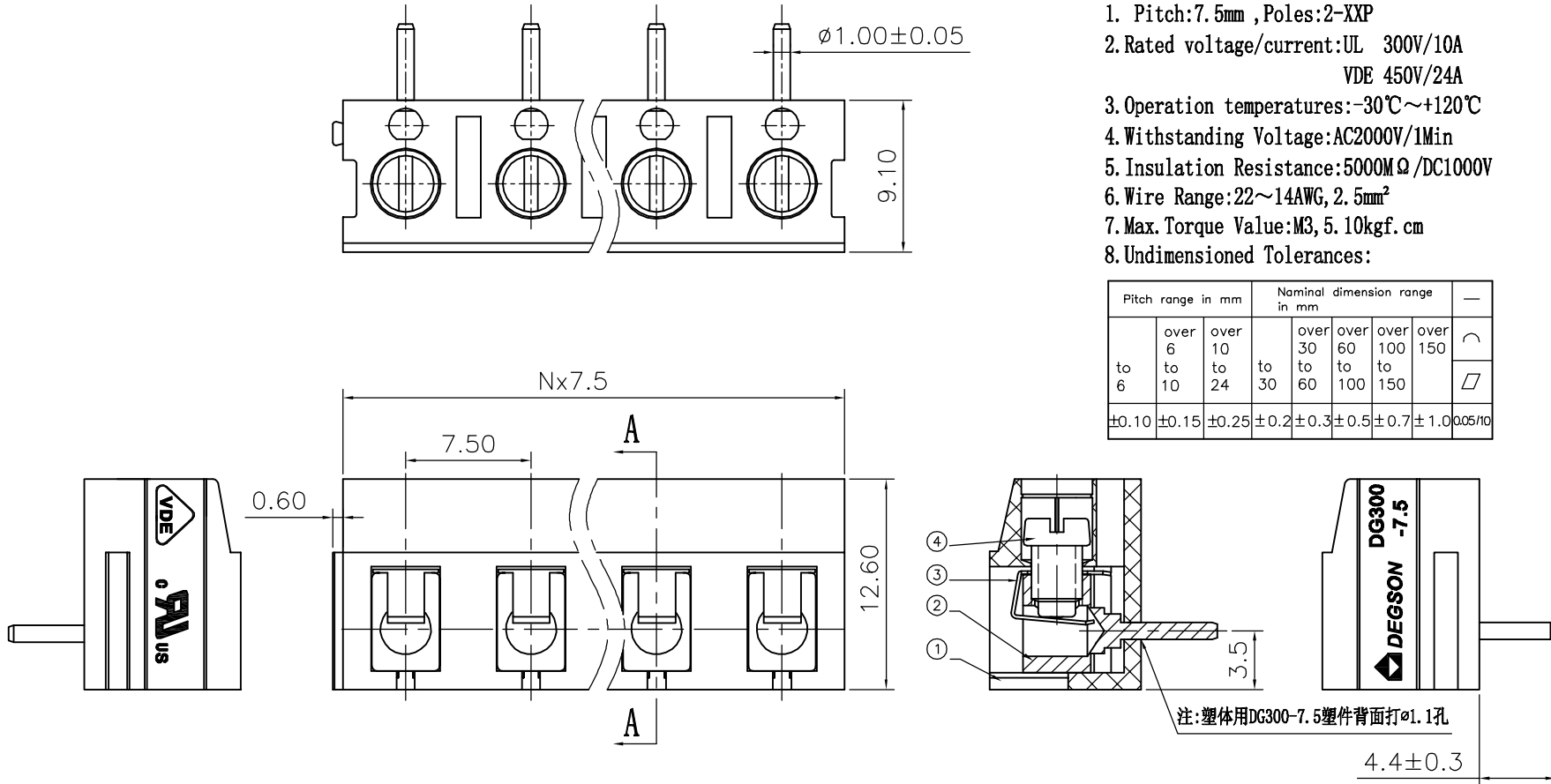

SECTION A-A

4	DG300"-Screws (M3*5.3)	S000001380 (H)	XX	Steel	Cr ³⁺ Zn
3	DG300-Spring	X000000230 (H)	XX	Stainless steel	
2	DG300R-Pin header	4002B00010 (H)	XX	Brass	SnCe

ITEM	NAME OF PART	NO. OF PART	Q'TY	MATERIAL	NOTES
1	DG300-7.5 Housing	4001A0YXXA (H)	1	PBT	UL94V-0

DETAILED LISTS	MM (INCH)	DFTO LJH	DATE 04/16/08*
		CHKD	DATE
		MFO	DATE
		APPVL	DATE
	MM		
	.0 ±	±	
	.00 ±	±	
	.000 ±	±	
		MATERIAL :	
	ANGLES ± 1'	G.E :	
	THIRD ANGLE PROJECTION	FINISH :	
		SCALE : 1:1	

宁波高正电子有限公司 DEGSON ELECTRONICS CO., LTD	
NAME	
DG300R-7.5-XXP-1Y-00A(H)	
DRAWING NO. DG300R-7.5-E01	SIZE A3
/PART NO.	REV TO 04/16/08*
DO NOT SCALE DRAWING	SHEET 1 OF 1