

Dół:

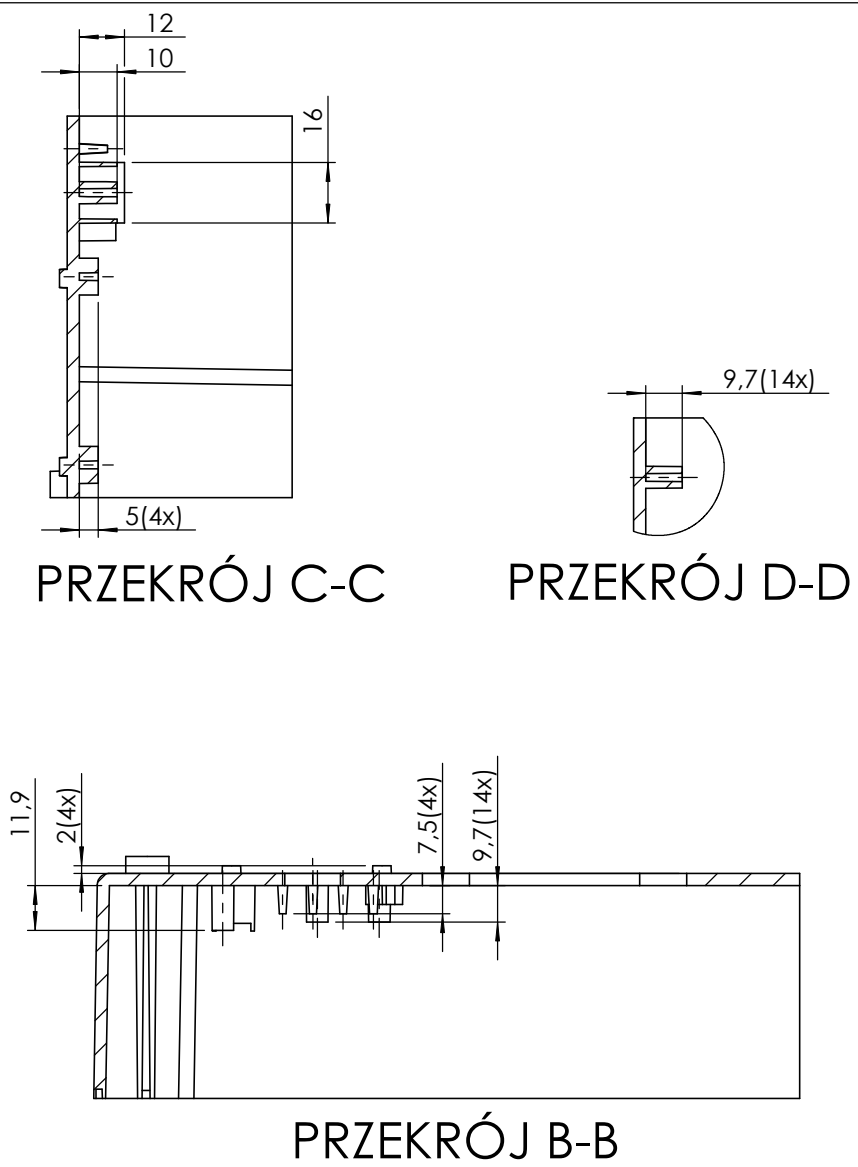

Obudowa:

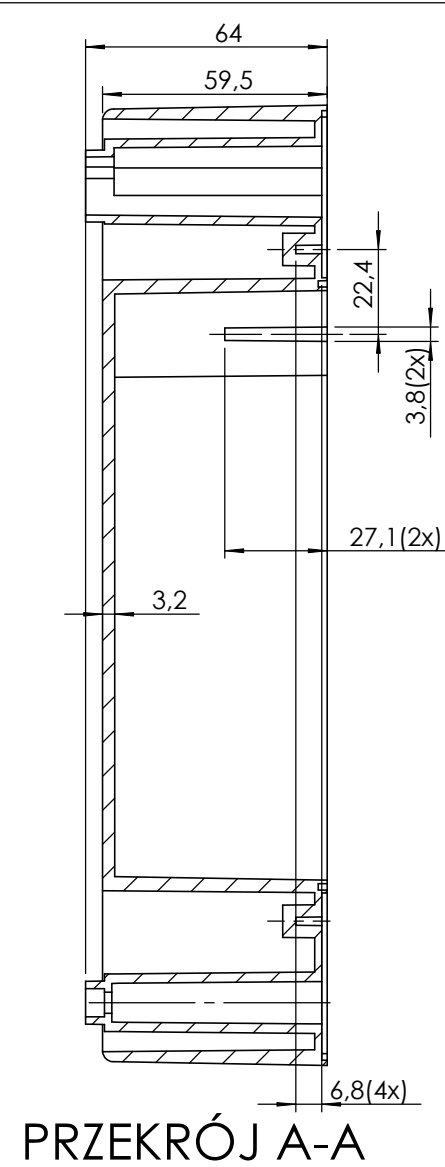
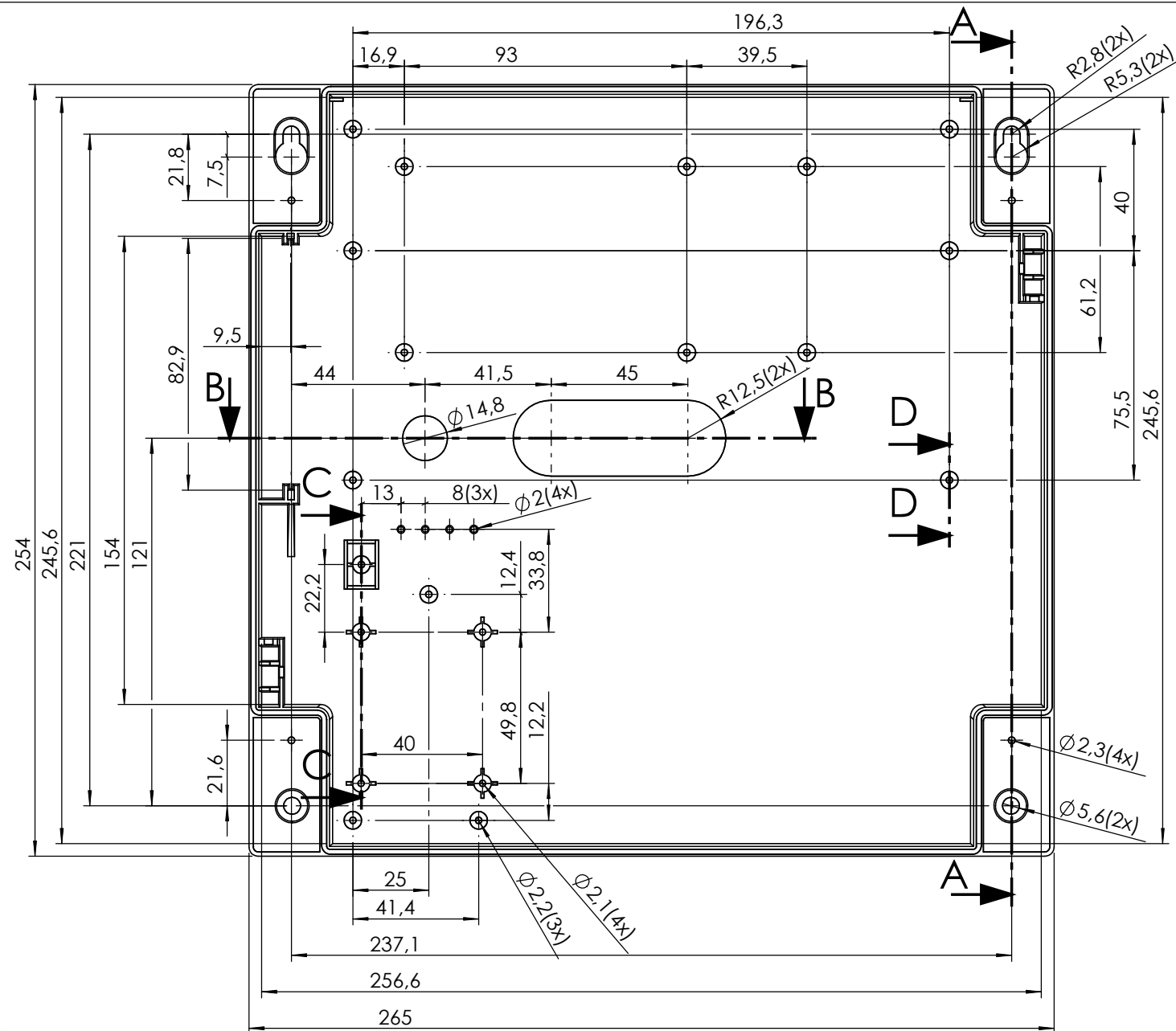
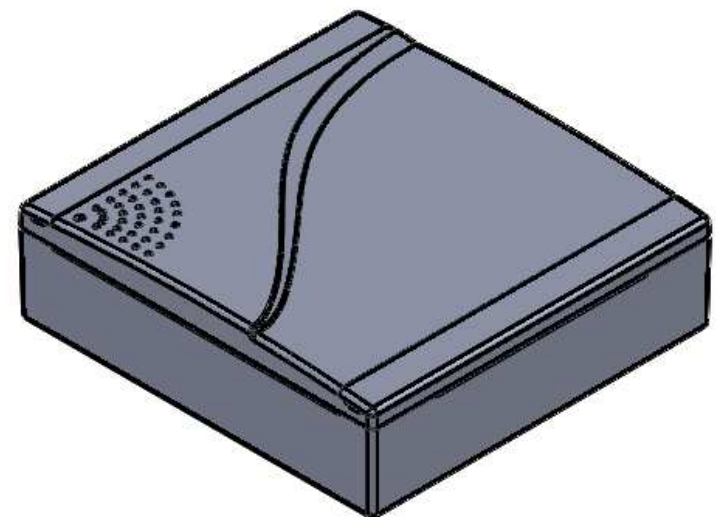
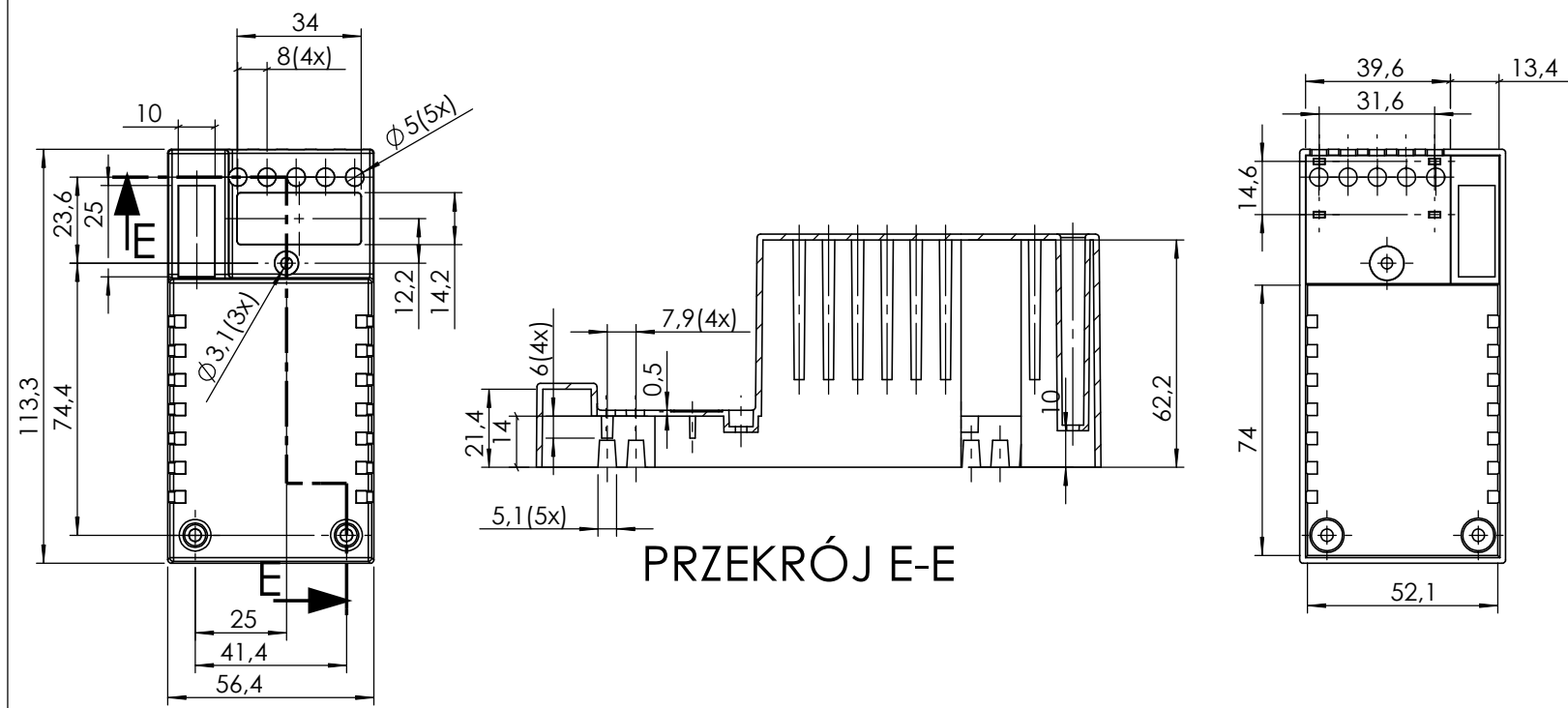

- Elementy składowe:
 - obudowa góra,
 - obudowa dół,
 - obudowa,
 - zaślepka 2x,

UWAGA: Wymiary w tolerancji $\pm 0,5\text{mm}$

Format	Skala
A3	1:2

Nr produktu
 KM-150B



Maszczyk
 05-071 Sulejówek-Mitosna
 ul. Mickiewicza 10
 tel.: (022)783 45 20, fax.: (022)783 90 85
 kom: 0602 726 086

maxPCB: 250mm x 240mm

Góra:

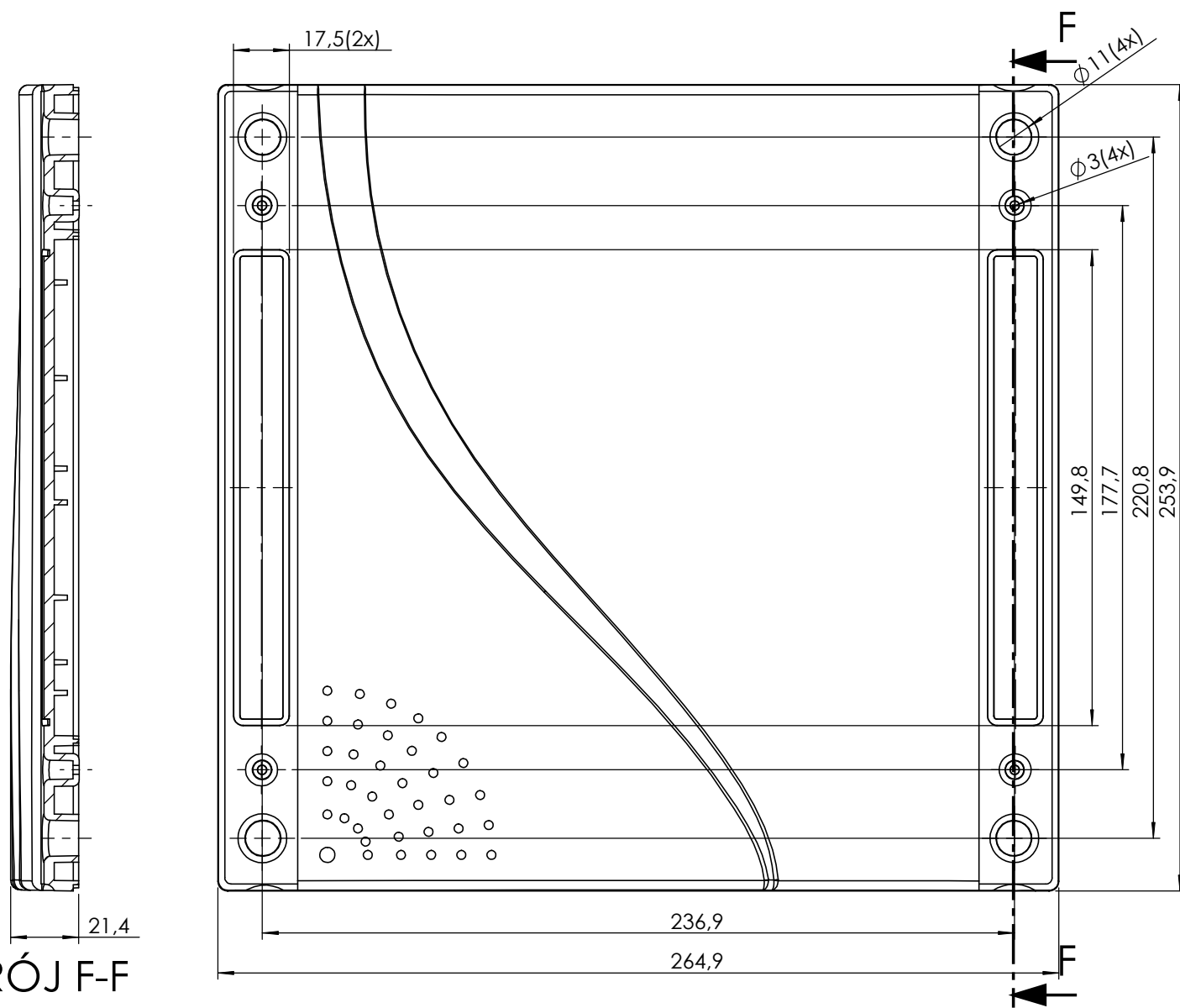

PRZEKRÓJ F-F

Zaślepka:

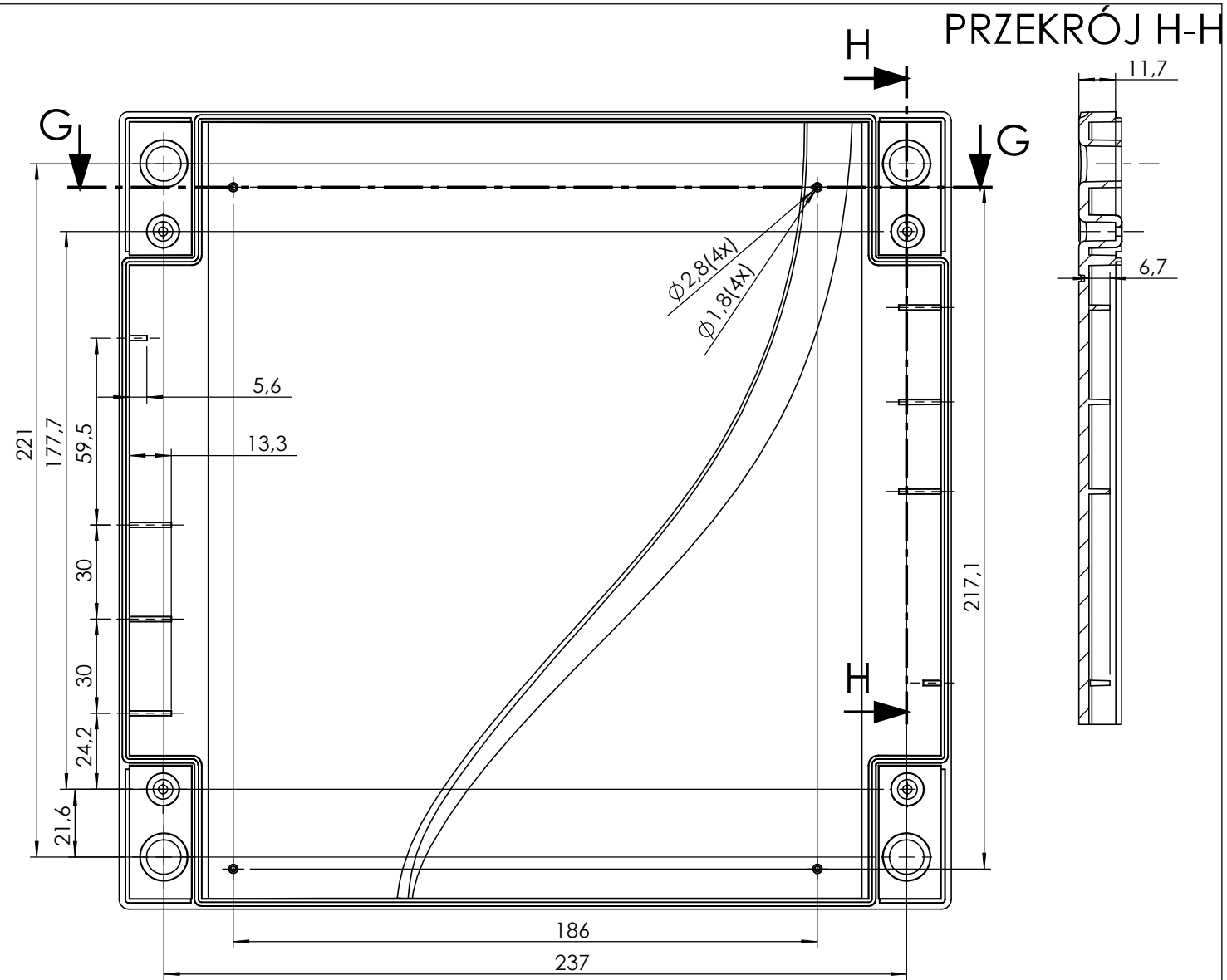
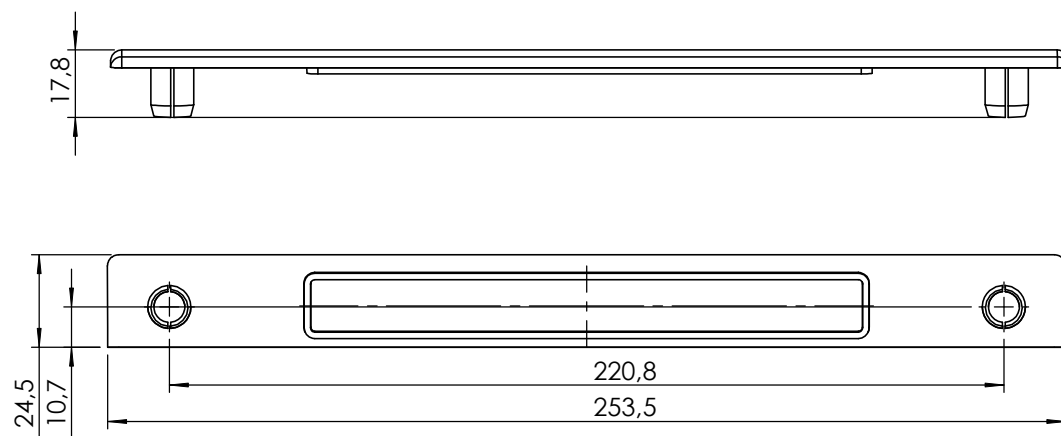

PRZEKRÓJ G-G

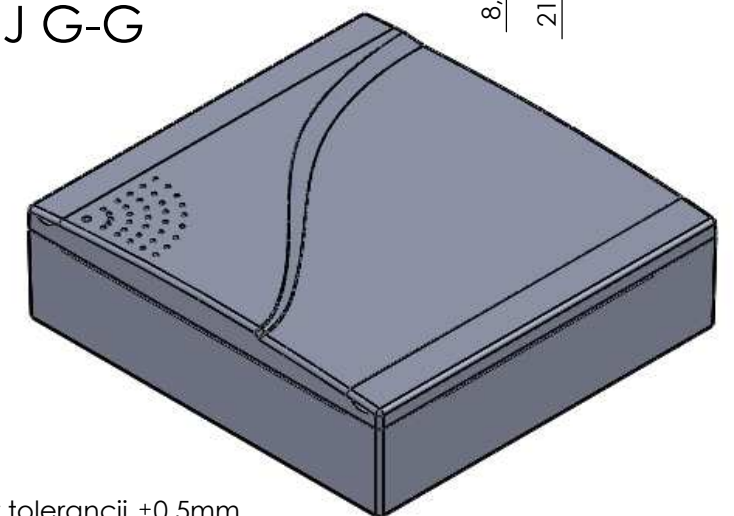

UWAGA: Wymiary w tolerancji $\pm 0,5\text{mm}$

- Elementy składowe:
- obudowa góra,
 - obudowa dół,
 - obudowa,
 - zaślepka 2x,

maxPCB: 250mm x 240mm

Format	Skala
A3	1:2
Nr produktu	
KM-150B	



Maszczyk
05-071 Sulejówek-Mitosna
ul. Mickiewicza 10
tel.: (022)783 45 20, fax.: (022)783 90 85
kom: 0602 726 086