

REVISION RECORD				
REV	ECN	DESCRIPTION	DRFT	DATE

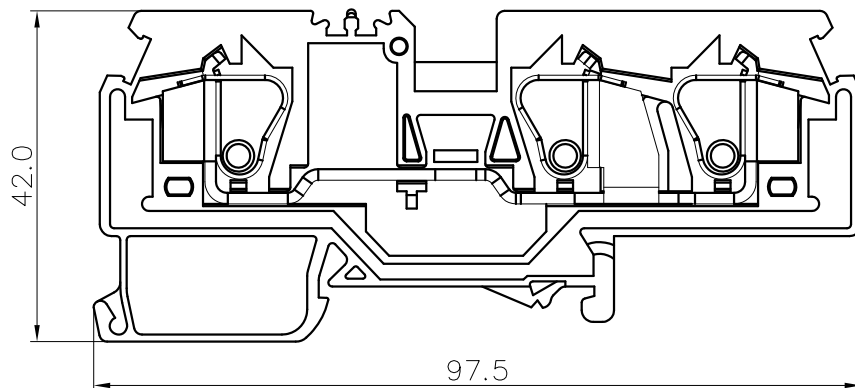
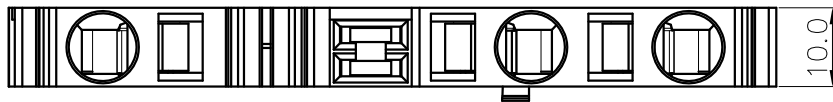
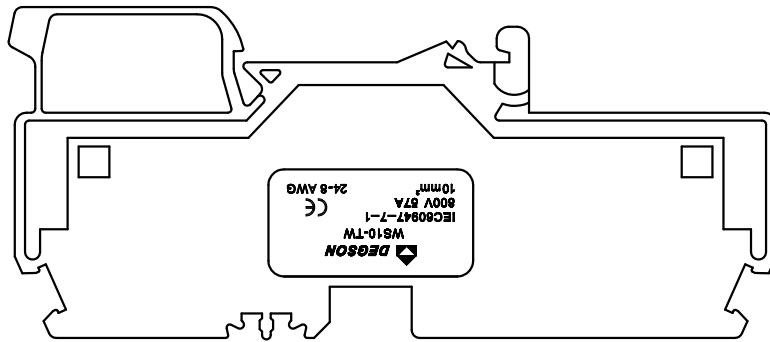

NOTES1:

UL Standard

1. Rated voltage/current : 600V / 50A
2. Withstanding voltage : AC2200V/1Min.
3. Wire range : 24~8AWG

IEC Standard

1. Pollution degree	3
Overtoltage category	III
Rate impulse voltage(KV)	8.0KV
Rate voltage(V)	800V
Rate current(A)	57 A

2. Wire range : 0.2~10mm²

NOTES2:

1. Dimension shall be interpreted per ASME Y14.5-2009
2. Pitch : 10.0mm, Poles : 01P
3. Stripping length : 13~14mm
4. Operating temperature: -40°C~+105°C
5. Undimensioned tolerances:

Pitch range in mm		Nominal dimension range in mm						—	∩	□
TO	Over	Over	Over	Over	Over	Over	0.1/10	∩	□	
6	6 TO 10	10 TO 24	TO 30	30 TO 60	60 TO 100	100 TO 150	<	∩	□	
±0.15	±0.20	±0.30	±0.30	±0.50	±0.70	±1.00	±1.30	±2'		

6. RoHS Compliance

WS10-TW - 01P - 1Y - 00A (H)
 (Series No.) (Poles) (Single Pitch) (Color): 1.(Grey)
 2.(Blue)
 3.(Black)
 4.(Green)
 5.(Orange)
 6.(Red)
 7.(Transparent)
 8.(Yellow)
 9.(White)

DETACHED LISTS	PART NO.:	宁波高松电子有限公司 NINGBO DEGSON ELECTRICAL CO., LTD			
	APPD:	NAME: WS10-TW-01P-1Y-00A(H)			
	CHKD:	TITLE: CUSTOMER DRAWING			
	DRFT:	DRAWING NO.:		REV	DO
	THIRD ANGLE PROJECTION		MM (INCH)	DO NOT SCALE DRAWING	SCALE: 1:1