

WS2.5T-DB...10AH/100AH

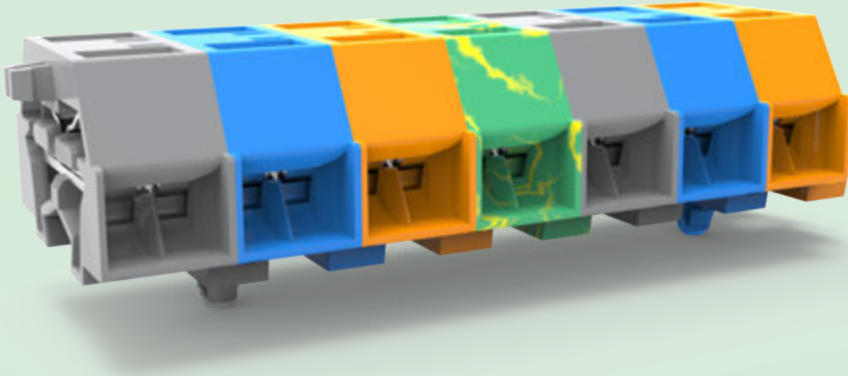

- 笼式弹簧结构，良好的抗振性；
- 提供带固定脚与不带固定脚两种规格；
- 标示面平整，满足快速贴纸要求；
- 最大线径:2.5mm²。
- Excellent shock proof performance thanks to the spring-cage structure;
- Provide two types : fixed foot and no fixed foot;
- Have smooth marking surfaces , meet the requirement of fast sticker;
- Max. wire range:2.5mm².

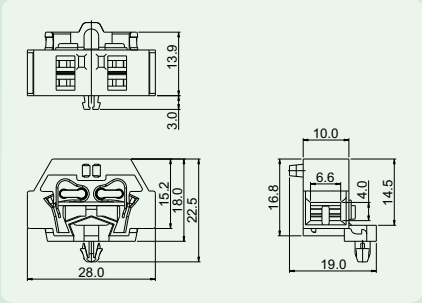

WS2.5T-DB-10AH

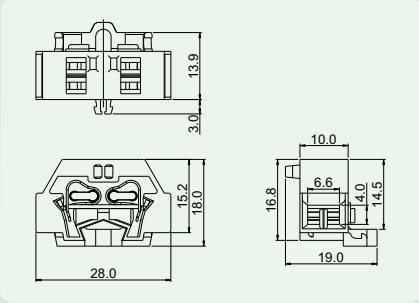

WS2.5T-DB-100AH

技术参数 Technical Data

APPROVAL: CE

型号 Model	线径 Wire range	线数 Poles	IEC60947技术参数 (IEC60947 datasheet)		UL1059技术参数 (UL1059 datasheet)	
			电压(V) Rated voltage	电流(A) Rated current	电压(V) Rated voltage	电流(A) Rated current
WS2.5T-DB-10AH	0.2-2.5mm ² /28-14AWG	1P-XXP	800	24	300	15
WS2.5T-DB-100AH	0.2-2.5mm ² /28-14AWG	1P-XXP	800	24	300	15

应用行业 Application

工业自动化、机械、电梯、电力电气等行业。
Industrial automation, machinery, elevator, electric power etc .



产品包装方式 Packing

Product model	Pcs./Pkt.
WS2.5T-DB-01P...10AH/100AH	100

型号对照 Cross Reference

DEGSON	同行1/ Competitor1	同行2/ Competitor2
WS2.5T-DB...10AH	261-1XX	—
WS2.5T-DB...100AH	261-1XX	—

产品订货 How to order

WS2.5T-DB — X X P — 1 1 — 1 0 AH

Series No. No. of Pole Customer Request

1 Single pitch
2 Double pitch

通用色	General Color	PANTONE	430C
1	Grey	DEGSON	01
2	Blue	PANTONE	3015U
8	Yellow	DEGSON	108C
5	Orange	PANTONE	167C
		DEGSON	08
		PANTONE	167C
		DEGSON	05