

REVISION RECORD				
REV	ECN	DESCRIPTION	DRFT	DATE

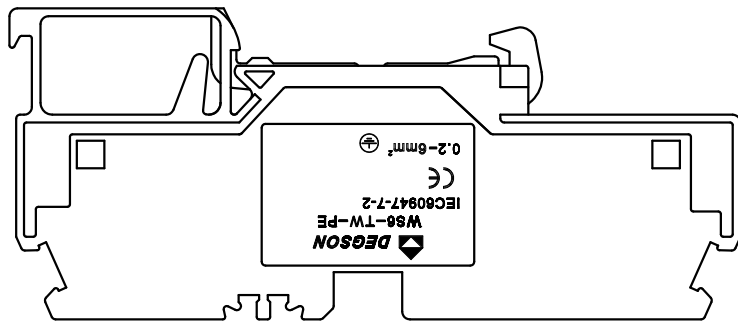
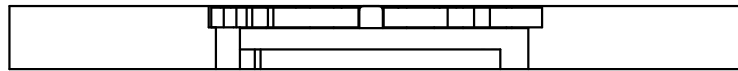
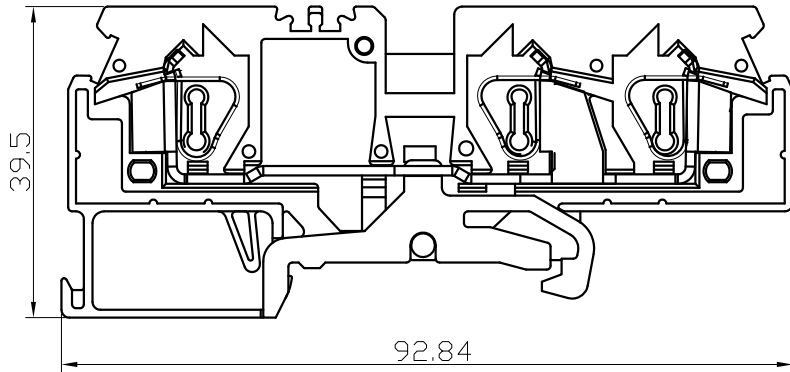

NOTES1:

UL Standard

1.Wire range : 24~10AWG

IEC Standard

1.

Pollution degree	3
Overtoltage category	III
Rate impulse voltage(KV)	8.0KV
Rate voltage(V)	/ V
Rate current(A)	/ A

2.Wire range : 0.2~6mm<sup>2</sup>

NOTES2:

1.Dimension shall be interpreted per ASME Y14.5-2009

2.Pitch : 8.0mm, Poles : 01P

3.Stripping length : 13~14mm

4.Operating temperature: -40°C~+105°C

5.Undimensioned tolerances:

Pitch range in mm		Nominal dimension range in mm						∓	∩	∇
TO	Over	Over	TO	Over	Over	Over	Over	0.1/10	<	
6	6	10	30	60	100	150	150			
±0.15	±0.20	±0.30	±0.30	±0.50	±0.70	±1.00	±1.30	±2'		

6.RoHS Compliance

WS6-TW-PE - 01P - 1C - 00A (H)  
 (Series No.) (Poles) (Single Pitch) (Color):(Yellow-Green)  
 (RoHS)  
 00A-(Standard)

DETACHED LISTS	PART NO.:	宁波高松电子有限公司 NINGBO DEGSON ELECTRICAL CO., LTD			
	APPD:	NAME: WS6-TW-PE-01P-1C-00A(H)			
	CHKD:	TITLE: CUSTOMER DRAWING			
	DRFT:	DRAWING NO.:		REV	DO
	THIRD ANGLE PROJECTION		MM (INCH)	DO NOT SCALE DRAWING	SCALE 1:1